

The information in this document is subject to change without notice and should not be construed as a commitment by ABB. ABB assumes no responsibility for any errors that may appear in this document.

Except as may be expressly stated anywhere in this document, nothing herein shall be construed as any kind of guarantee or warranty by ABB for losses, damages to persons or property, fitness for a specific purpose or the like.

In no event shall ABB be liable for incidental or consequential damages arising from use of this document.

This document and parts thereof must not be reproduced or copied without ABB's written permission, and contents thereof must not be imparted to a third party nor be used for any unauthorized purpose. Contravention will be prosecuted.

Additional copies of this document may be obtained from ABB at its then current charge.

© Copyright 2024 ABB ALL right reserved.

ABB Engineering (Shanghai) Ltd
No.4528, Kangxin Highway,Kangqiao Town
Pudong New District, Shanghai, 201319
P.R.China

Latest revision:
Add page 17 for valve version
Adjust C2 harness connection to page 18

Prepared by, date: 10021267

Approved by, date: 10126686



Lab/Office:
RA/RDP

IRB1300
COPYRIGHT PAGE

Status:
Approved

Plant: =
Location: +
Sublocation: +

Document no.
3HAC068887-003

Rev. Ind
05
Page 1
Next 2
Total 18

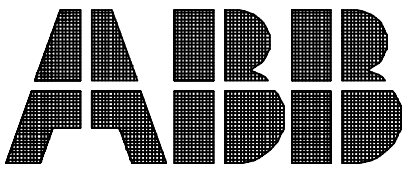

Description : IRB1300
 Drawing number : 3HAC068887-003
 Drawing version : 05
 Date :

Customer :
 Year of construction :
 :
 :
 :
 :
 :
 :

Drawn by : 10021267
 Number of pages : 18
 :
 :
 :
 :

All rights reserved in this document shall be information contained herein is reproduced, use or disclosure to third parties without express authority is strictly forbidden. © Copyright 2024 ABB

Latest revision: Add page 17 for valve version Adjust C2 harness connection to page 18			Lab/Office: RA/RDP	IRB1300 TITLE PAGE	Status: Approved	Plant: = Location: + Sublocation: +	Document no. 3HAC068887-003	Rev. Ind 05	Page 2 Next 3 Total 18
					Prepared by, date: 10021267	Approved by, date: 10126686			

TABLE OF CONTENTS

PAGE	PAGE DESCRIPTION	Date	Edited by
/1	COPYRIGHT PAGE	06/06/2019	CNFRLIA1
/2	TITLE PAGE	06/06/2019	CNFRLIA1
/3	TABLE OF CONTENTS	05/19/2020	CNXIDEN3
/4	VALID FOR	05/18/2020	CNXIDEN3
/5	REVISION INFORMATION	05/18/2020	CNXIDEN3
/6	SYSTEM OVERVIEW	05/19/2020	CNXIDEN3
/7	CONNECTION POINT LOCATION	05/18/2020	CNXIDEN3
/8	BRAKE RELEASE UNIT	01/13/2022	CNXIDEN3
/9	SERIAL MEASUREMENT BOARD	05/18/2020	CNXIDEN3
/10	AXIS 1	07/10/2020	CNXIDEN3
/11	AXIS 2	05/19/2020	CNXIDEN3
/12	AXIS 3	05/19/2020	CNXIDEN3
/13	AXIS 4	05/19/2020	CNXIDEN3
/14	AXIS 5	05/19/2020	CNXIDEN3
/15	AXIS 6	05/19/2020	CNXIDEN3
/16	CUSTOMER CONNECTION - STANDARD	01/27/2021	CNXIDEN3
/17	CUSTOMER CONNECTION - VALVE	02/02/2024	CNXIDEN3
/18	ETHERNET CONNECTION	01/27/2021	CNXIDEN3

All rights reserved. In this document, the information contained therein is confidential, use or disclosure to third parties without express authority is strictly prohibited. © Copyright 2024, ABB

Latest revision:
 Add page 17 for valve version
 Adjust C2 harness connection to page 18

 Prepared by, date: 10021267 Approved by, date: 10126686



Lab/Office:
 RA/RDP

IRB1300
 TABLE OF CONTENTS

Status:	Approved	Plant:	=	Location:	+	Sublocation:	+
Document no.		Rev. Ind	05	Page 3		Next 4	
3HAC068887-003				Total 18			

Valid for:

This circuit diagram is valid for the following cable harness & board unit assemblies:

Cable harness for IRB1300:

- 3HAC067161-004 Main Harness,S,Basic
- 3HAC067161-005 Main Harness,S,Basic+Air+C1
- 3HAC067161-006 Main Harness,S,Basic+Air+C1+C2+C3
- 3HAC067161-007 Main Harness,M,Basic
- 3HAC067161-008 Main Harness,M,Basic+Air+C1
- 3HAC067161-009 Main Harness,M,Basic+Air+C1+C2+C3
- 3HAC067161-010 Main Harness,L,Basic
- 3HAC067161-011 Main Harness,L,Basic+Air+C1
- 3HAC067161-012 Main Harness,L,Basic+Air+C1+C2+C3

3HAC067163-001 Brake Release Unit

- 3HAC067164-004 Process Hub, Basic
- 3HAC067164-005 Process Hub, Basic+Air+C1
- 3HAC067164-006 Process Hub, Basic+Air+C1+C2+C3
- 3HAC072628-004 Process Hub, Basic+Air+C1+C2+C3+Valve

Board unit for IRB1300:

3HAC065316-001 SMB Unit

We reserve rights in this document until the information contained herein is approved, use or disclosure to third parties without express authority is strictly forbidden. © Copyright 2004 ABB

Latest revision: Add page 17 for valve version Adjust C2 harness connection to page 18		Lab/Office: RA/RDP	IRB1300 VALID FOR	Status:	Plant: =	
				Approved	Location: + Sublocation: +	
Prepared by, date: 10021267	Approved by, date: 10126686			Document no. 3HAC068887-003	Rev. Ind 05	Page 4 Next 5 Total 18

2020-05-20 First version Ver00

2020-07-10 Rev01

Page 10 Revise R1.MP connectors to 1,2,5

2020-08-14 Rev02

Page 10-15,17 Add twisted cable mark for motor phase/brake/Ethernet cable

Page 16 Change C3 maximum rating to 60V DC

2021-01-27 Rev03

Page 16 Change maximum rating in C3 wire to 42V DC

Add R1.C1 floor cable information

Page 17 Revise C2 twisted pairs to reference

2022-01-13 Rev04

Page 8 Change Brake Release Unit circuit

2024-02-02 Rev05

Add page 17 for valve version

Adjust C2 harness connection to page 18

Latest revision:
Add page 17 for valve version
Adjust C2 harness connection to page 18



Lab/Office:
RA/RDP

IRB1300
REVISION INFORMATION

Status:
Approved

Plant: =
Location: +
Sublocation: +

Document no.
3HAC068887-003

Rev. Ind
05

Page 5
Next 6
Total 18

Prepared by, date: 10021267

Approved by, date: 10126686

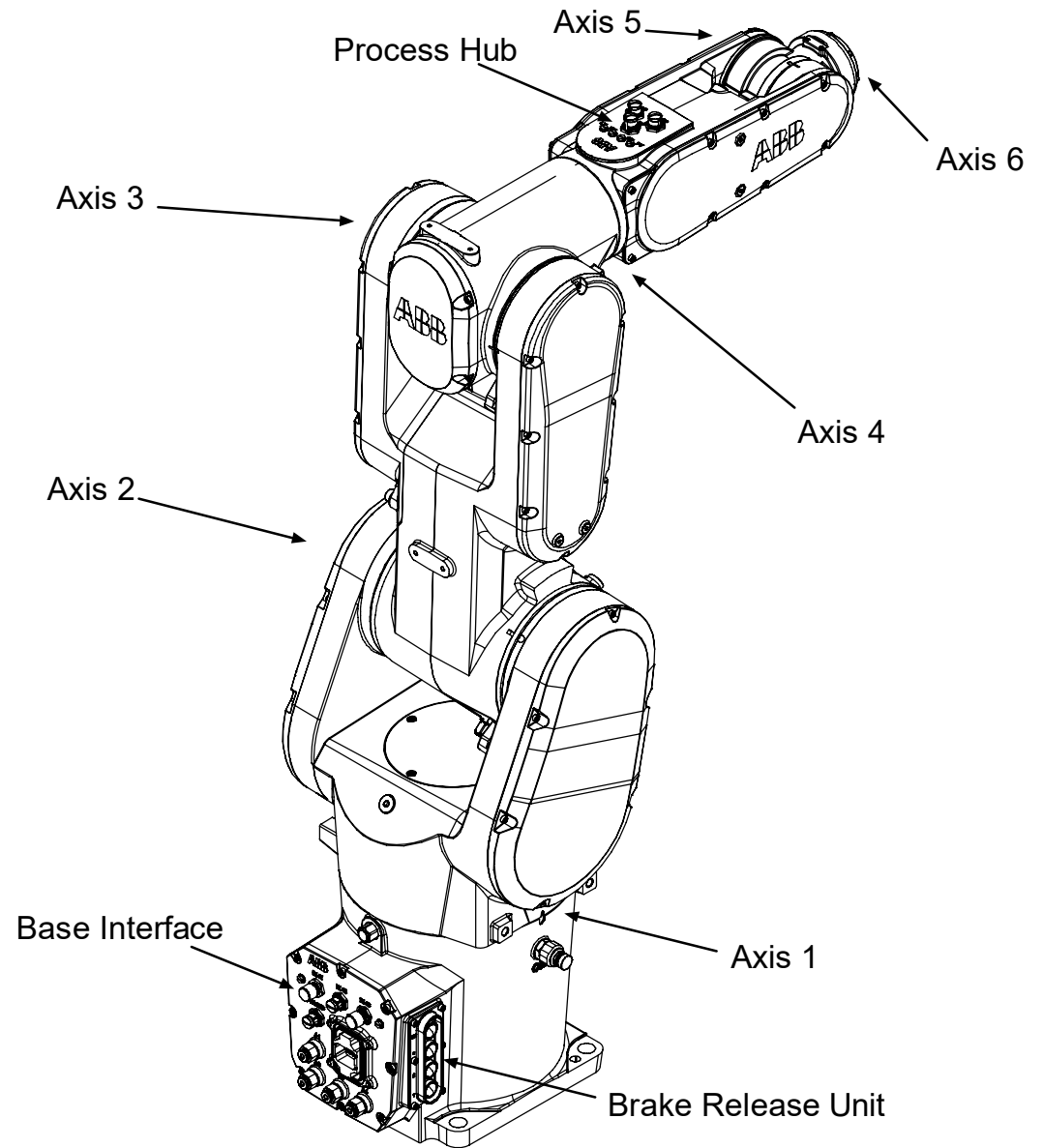
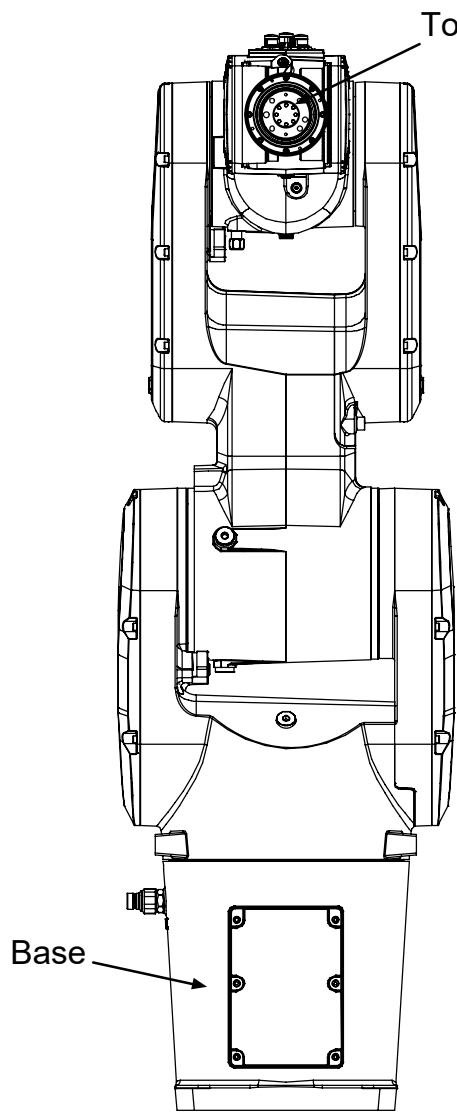

All rights reserved. In this document, all information is confidential. Any disclosure, use or reproduction of this document without express authority is strictly forbidden. © Copyright 2004 ABB

Latest revision:
 Add page 17 for valve version
 Adjust C2 harness connection to page 18

Prepared by, date: 10021267 Approved by, date: 10126686



Lab/Office:
 RA/RDP

IRB1300
 SYSTEM OVERVIEW

Status:	Plant: =	Rev. Ind	Page 6
Approved	Location: +	05	Next 7
Document no.	Sublocation: +		Total 18
3HAC068887-003			

All rights reserved in this document. All information contained herein is confidential. Use or disclosure to third parties without express authority is strictly forbidden. © Copyright 2024 ABB

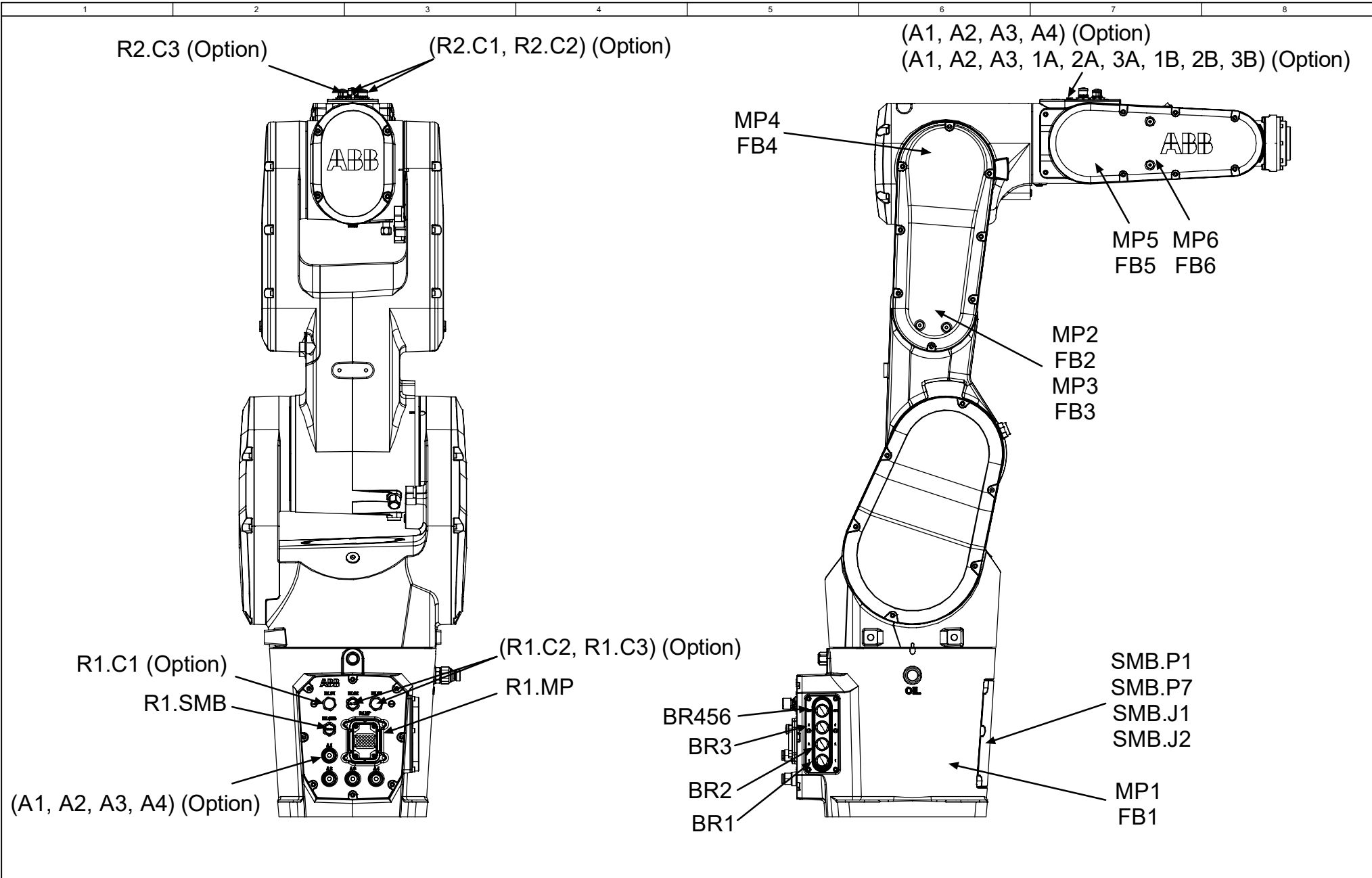

Latest revision:
 Add page 17 for valve version
 Adjust C2 harness connection to page 18

Prepared by, date: 10021267 Approved by, date: 10126686

ABB	Lab/Office: RA/RDP	IRB1300
	CONNECTION POINT LOCATION	

Status: Approved	Plant: = Location: + Sublocation: +
Document no. 3HAC068887-003	Rev. Ind 05
	Page 7 Next 8 Total 18

Brake Release Unit

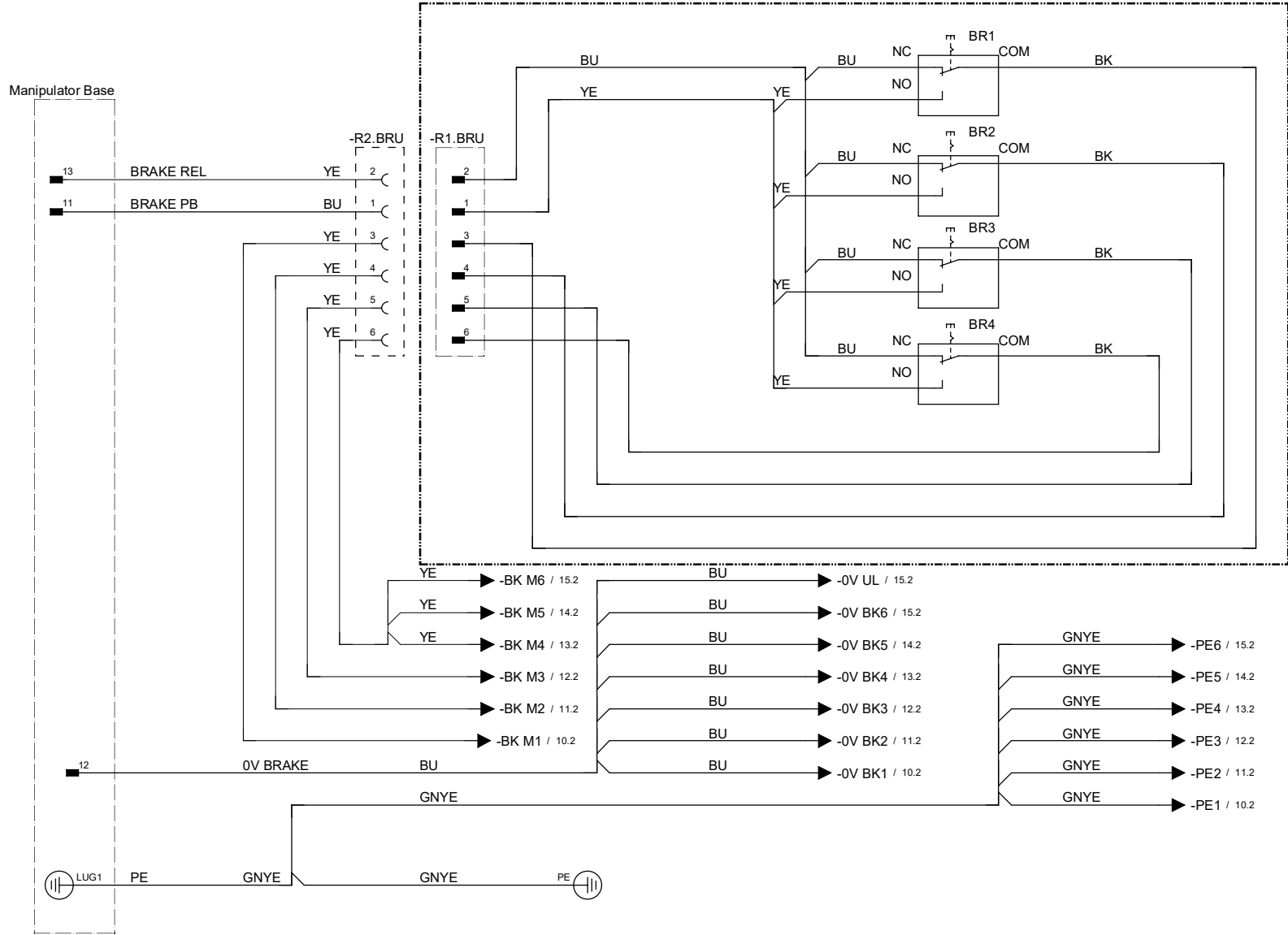

All rights reserved in this document shall be the information contained herein, its reproduction, use or disclosure to third parties without express authority is strictly forbidden. © Copyright 2024 ABB

Latest revision:
 Add page 17 for valve version
 Adjust C2 harness connection to page 18



Lab/Office:
 RA/RDP

IRB1300
 BRAKE RELEASE UNIT

Status:
 Approved

Plant: =
 Location: +
 Sublocation: +

Document no.
 3HAC068887-003

Rev. Ind	Page 8
05	Next 9
	Total 18

Prepared by, date: 10021267

Approved by, date: 10126686

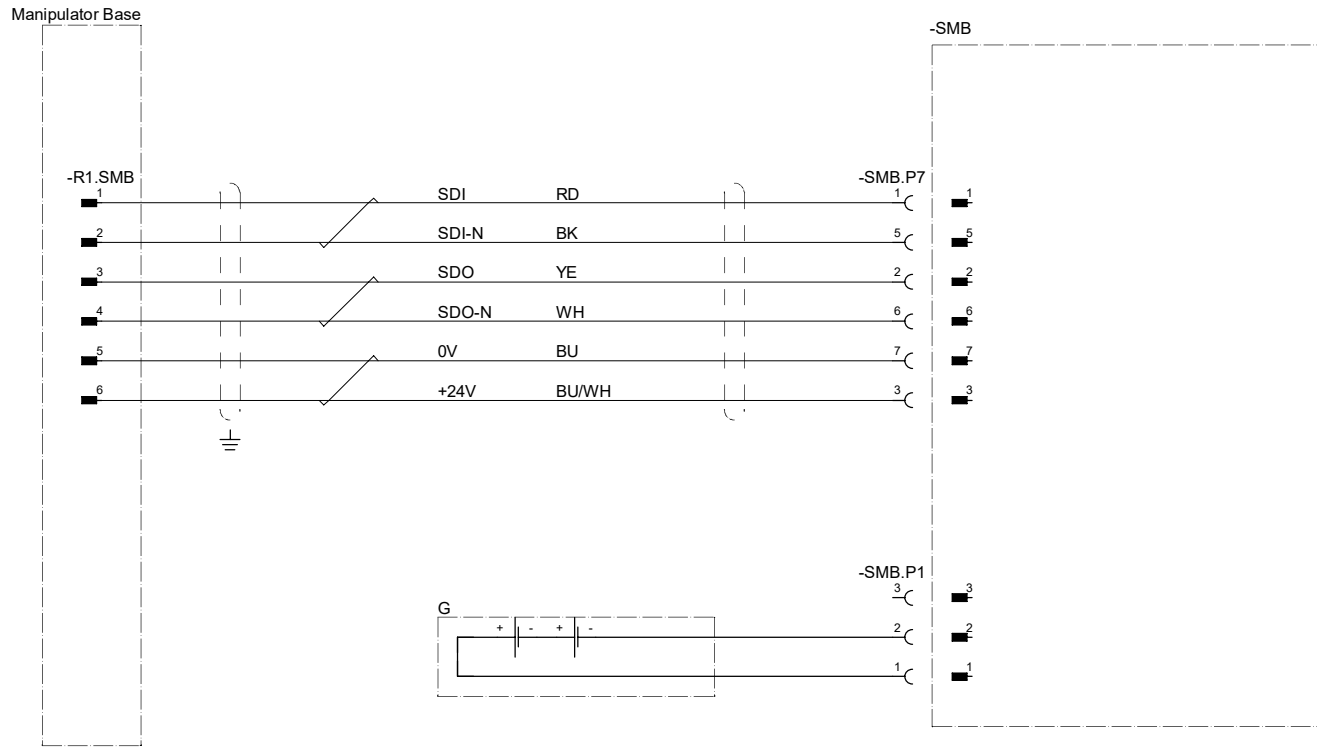

All rights reserved in this document shall be the information contained therein, reproduction, use or disclosure to third parties without express authority is strictly forbidden. © Copyright 2004 ABB

Latest revision:
Add page 17 for valve version
Adjust C2 harness connection to page 18



Lab/Office:
RA/RDP

IRB1300
SERIAL MEASUREMENT BOARD

Status:
Approved

Plant: =
Location: +
Sublocation: +

Document no.
3HAC068887-003

Rev. Ind	Page 9
05	Next 10
	Total 18

Prepared by, date: 10021267

Approved by, date: 10126686

Manipulator Base

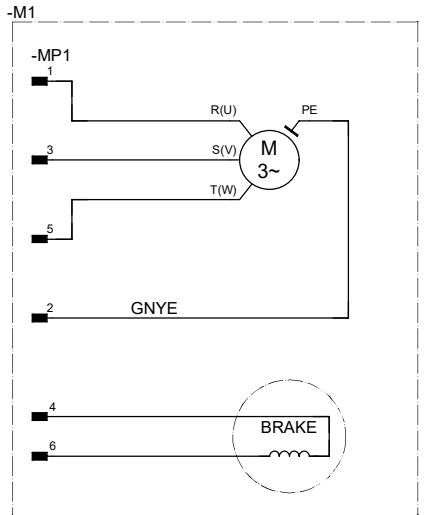
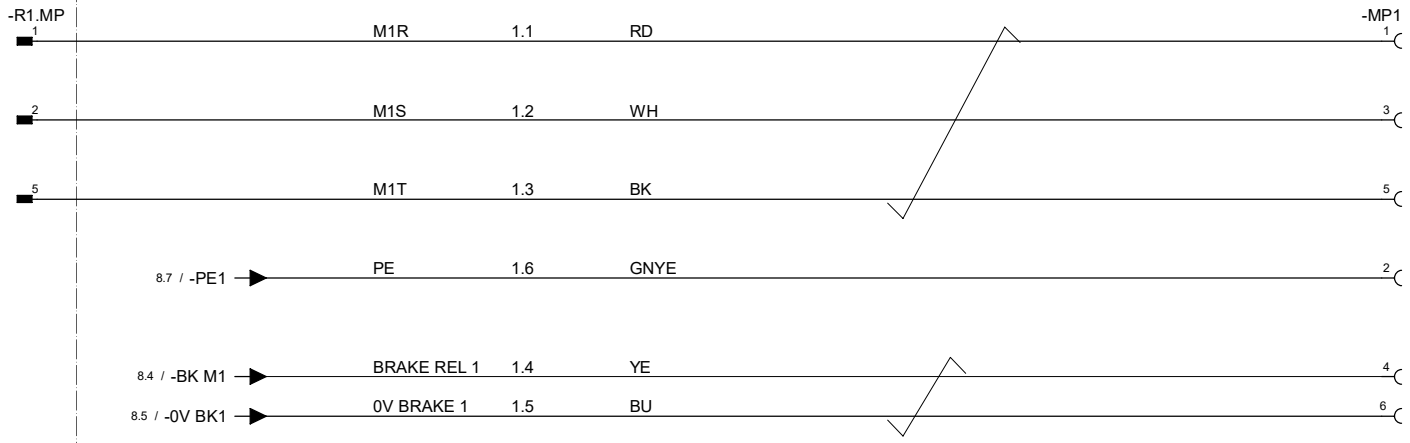

-SMB

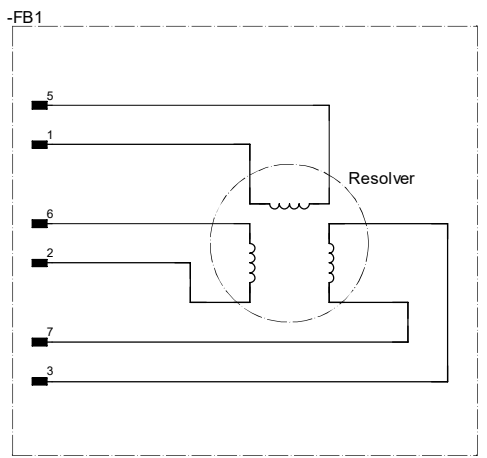
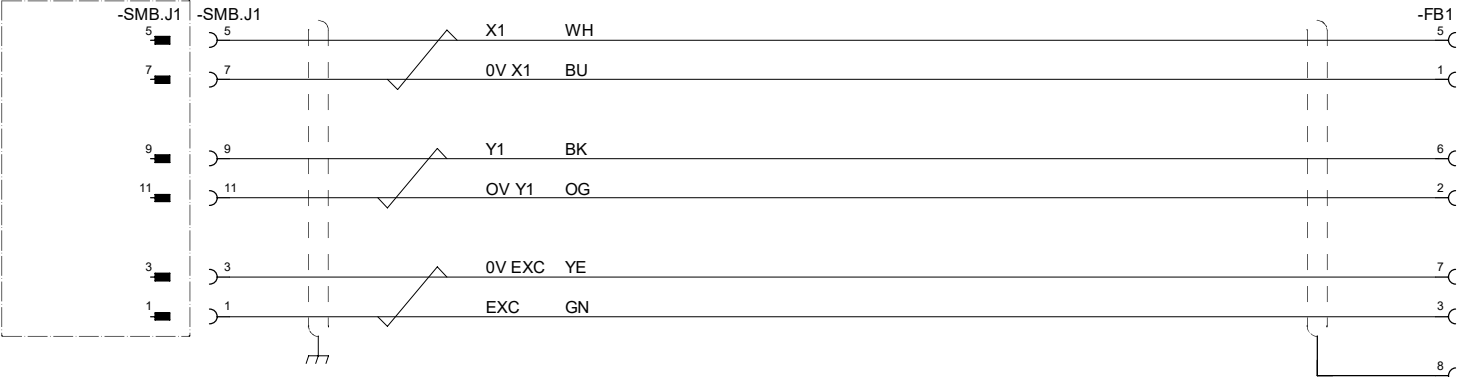

Latest revision:
Add page 17 for valve version
Adjust C2 harness connection to page 18



Lab/Office:
RA/RDP
IRB1300
AXIS 1

Status:
Approved

Plant: =
Location: +
Sublocation: +

Document no.
3HAC068887-003

Rev. Ind
05
Page 10
Next 11
Total 18

Prepared by, date: 10021267

Approved by, date: 10126686

We reserve rights in this document should the information contained therein be reproduced, use or disclosure to third parties without express authority is strictly forbidden. © Copyright 2024 ABB

We reserve rights in this document should the information contained herein be reproduced, use or disclosure to third parties without express authority is strictly forbidden. © Copyright 2024 ABB

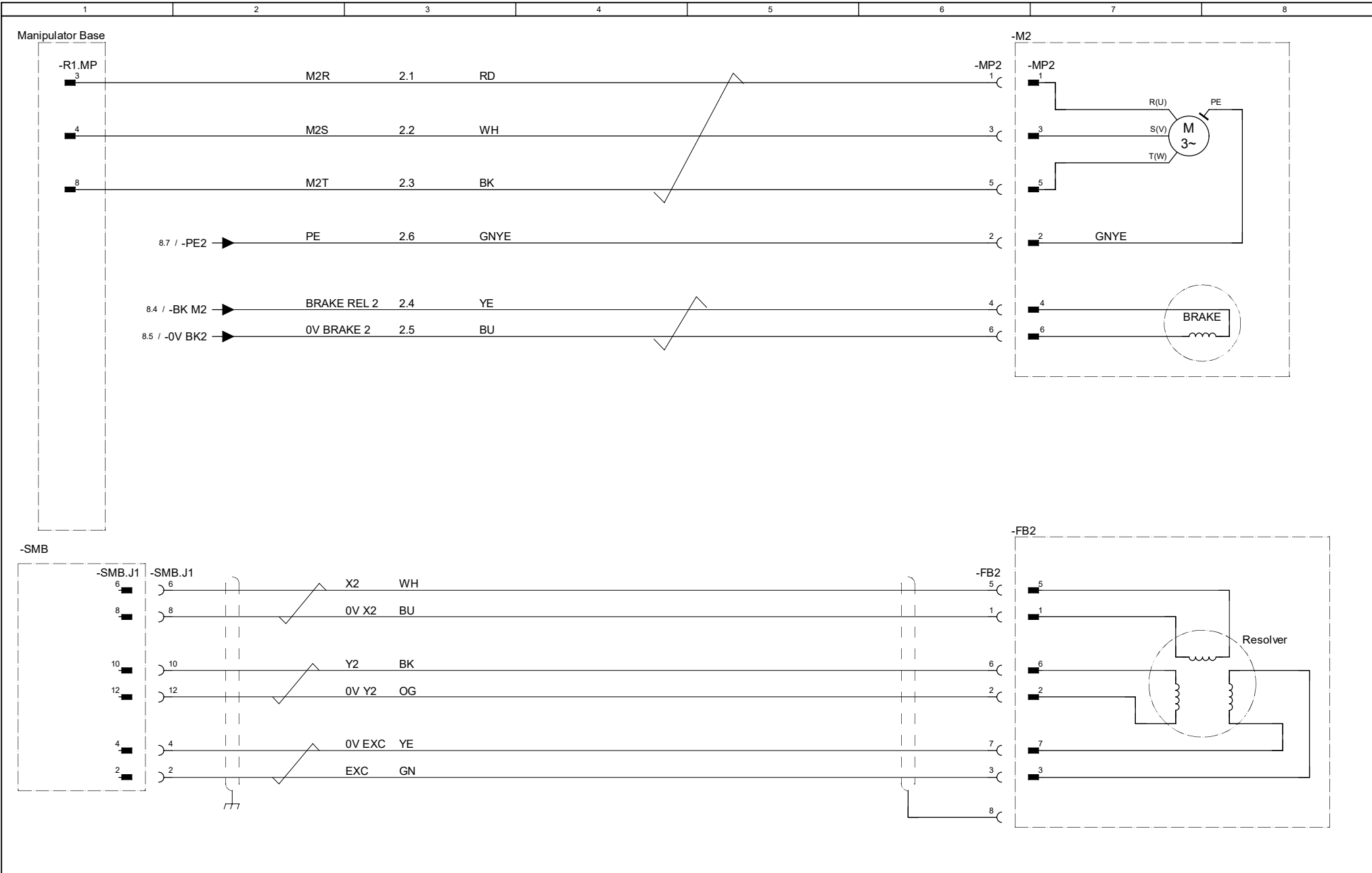

Latest revision:
 Add page 17 for valve version
 Adjust C2 harness connection to page 18

Prepared by, date: 10021267 Approved by, date: 10126686



Lab/Office:
RA/RDP

IRB1300
 AXIS 2

Status: Approved	Plant: Location: Sublocation:	= + +
Document no. 3HAC068887-003	Rev. Ind 05	Page 11 Next 12 Total 18

We reserve all rights in this document should the information contained herein be reproduced, used or disclosed to third parties without express authority is strictly forbidden. © Copyright 2024 ABB

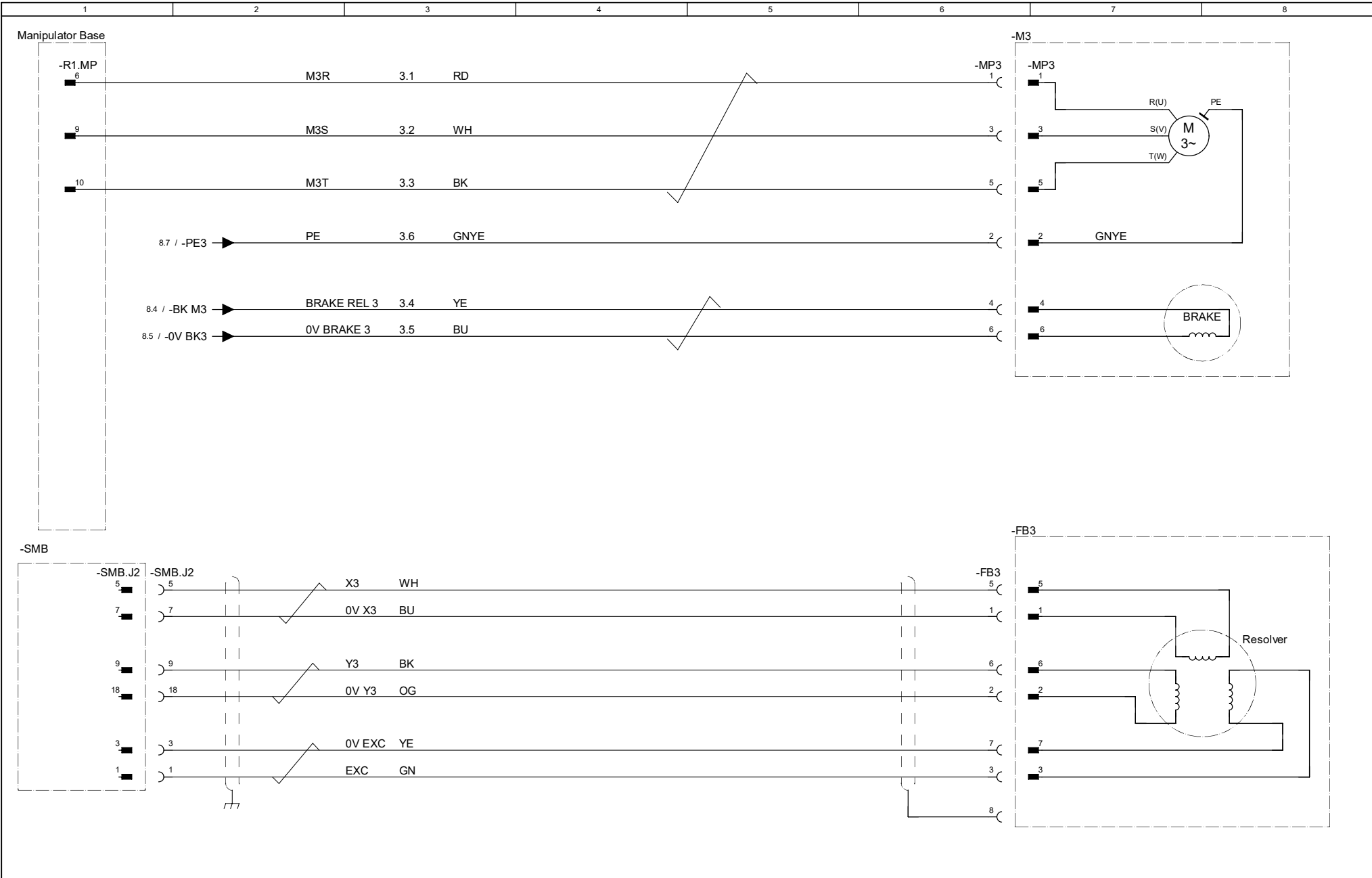

Latest revision:
 Add page 17 for valve version
 Adjust C2 harness connection to page 18

Prepared by, date: 10021267 Approved by, date: 10126686



Lab/Office:
RA/RDP

IRB1300
AXIS 3

Status: Approved	Plant: Location: Sublocation:	= + +
Document no. 3HAC068887-003	Rev. Ind 05	Page 12 Next 13 Total 18

Manipulator Base

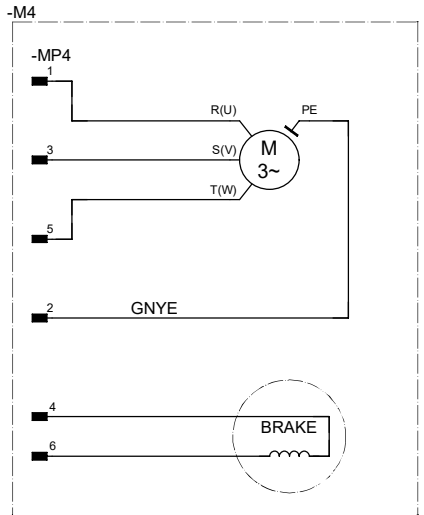
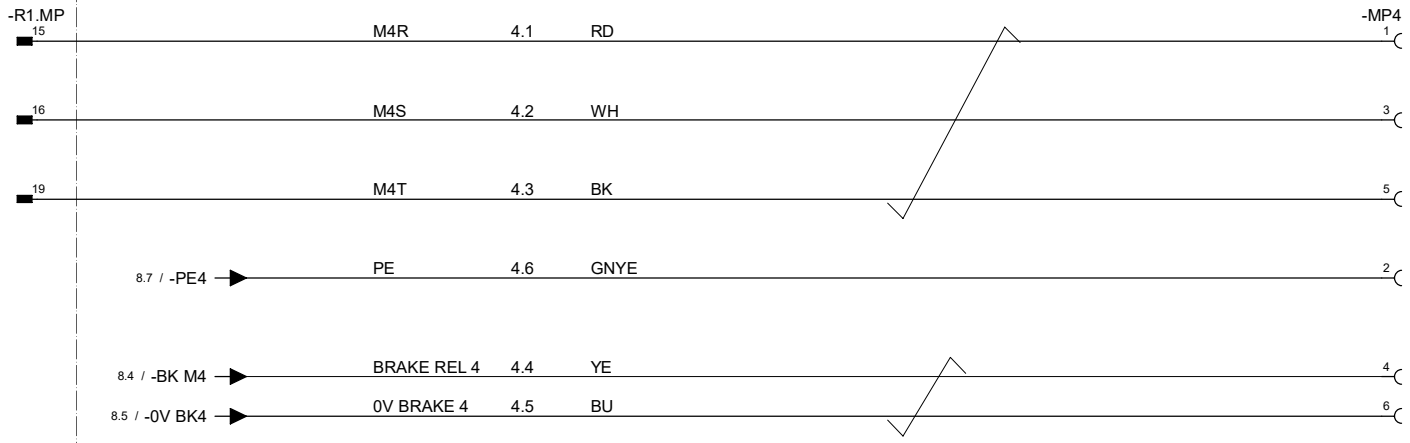

-SMB

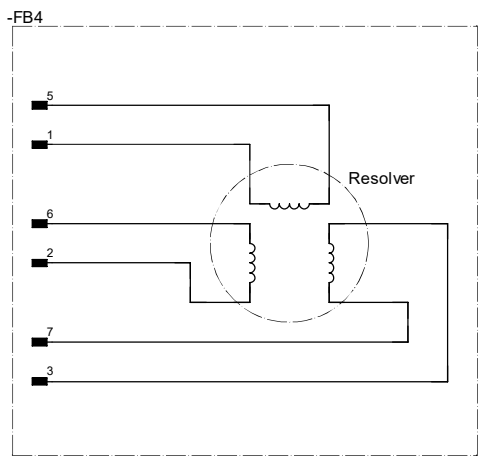
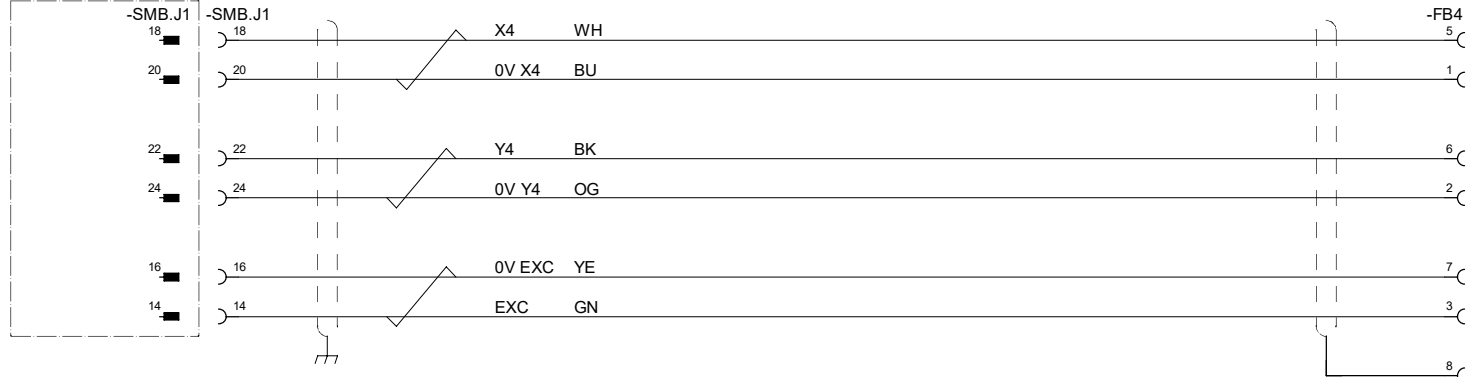

Latest revision:
 Add page 17 for valve version
 Adjust C2 harness connection to page 18

Prepared by, date: 10021267
 Approved by, date: 10126686

ABB Lab/Office: RAI/RDP
 IRB1300
 AXIS 4

Status: Approved	Plant: = Location: + Sublocation: +
Document no. 3HAC068887-003	Rev. Ind 05
	Page 13 Next 14 Total 18

We reserve rights in this document should the information contained therein be reproduced, use or disclosure to third parties without express authority is strictly forbidden. © Copyright 2024 ABB

Manipulator Base

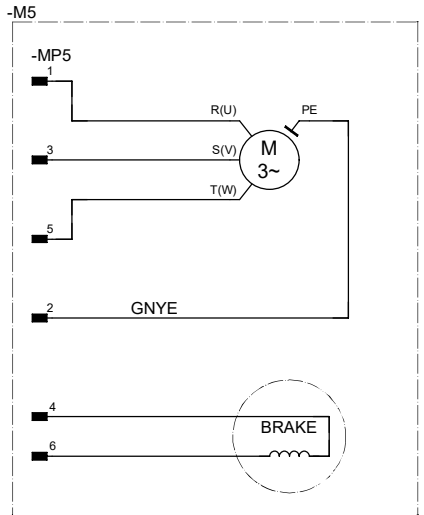
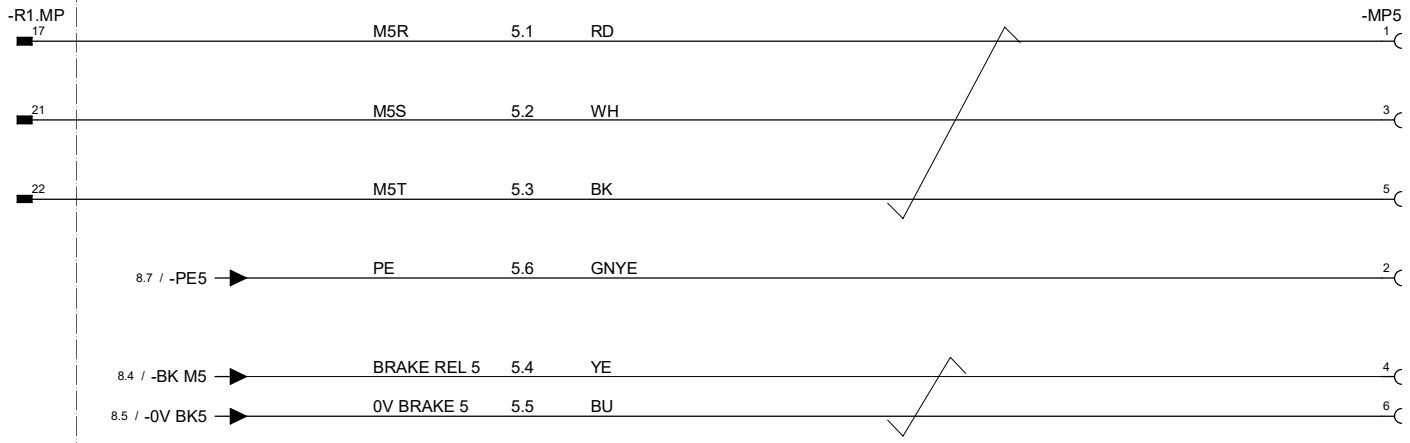

-SMB

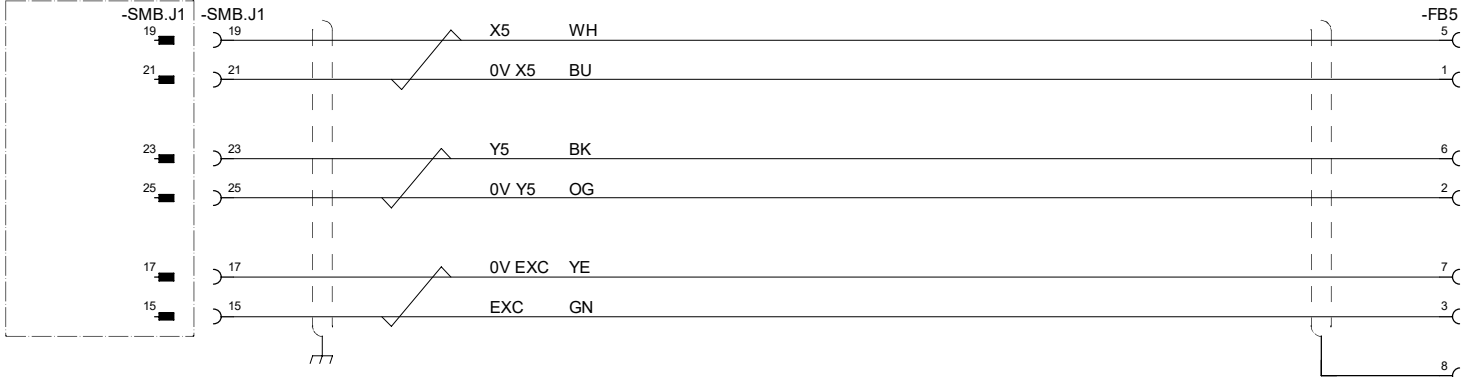

-FB5

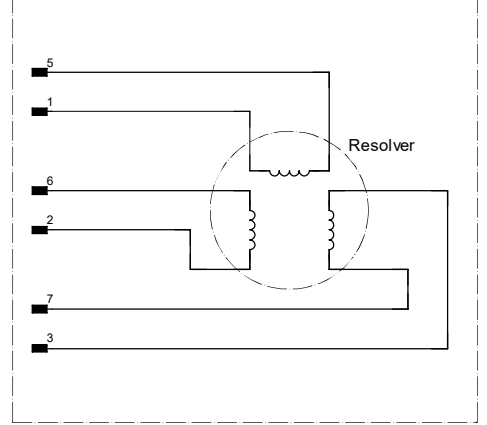

Latest revision:
Add page 17 for valve version
Adjust C2 harness connection to page 18



Lab/Office:
RA/RDP
IRB1300
AXIS 5

Status:
Approved

Plant: =
Location: +
Sublocation: +

Document no.
3HAC068887-003

Rev. Ind
05
Page 14
Next 15
Total 18

Prepared by, date: 10021267

Approved by, date: 10126686

We reserve rights in this document should the information contained therein be reproduced, use or disclosure to third parties without express authority is strictly forbidden. © Copyright 2024 ABB

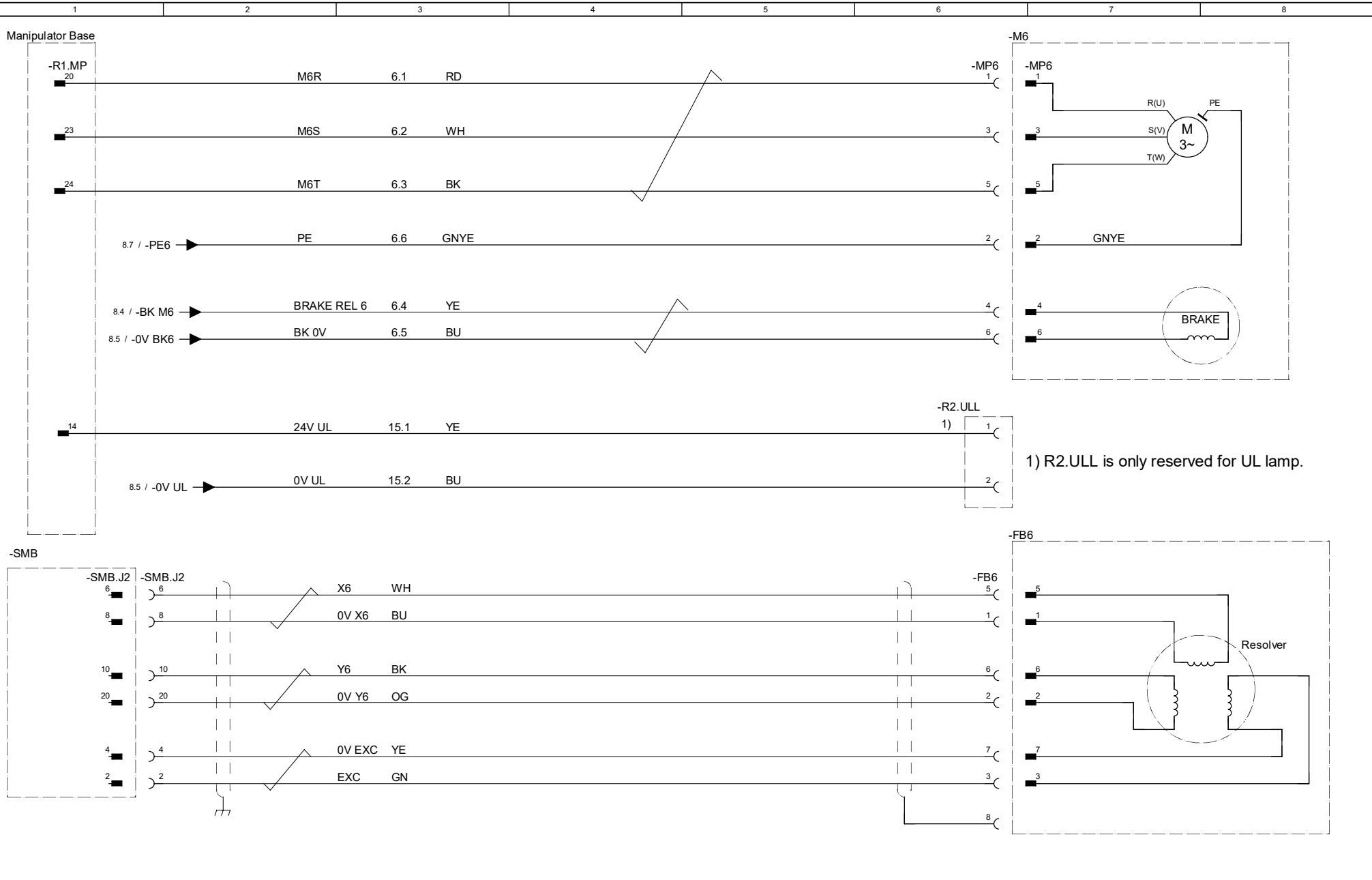

1) R2.ULL is only reserved for UL lamp.

Latest revision:
 Add page 17 for valve version
 Adjust C2 harness connection to page 18

Prepared by, date: 10021267

Approved by, date: 10126686



Lab/Office:
RA/RDP

IRB1300
 AXIS 6

Status:
 Approved

Plant: =
 Location: +
 Sublocation: +

Document no.
 3HAC068887-003

Rev. Ind
 05

Page 15
 Next 16
 Total 18

We reserve rights in this document should the information contained herein be reproduced, use or disclosure to third parties without express authority is strictly forbidden. © Copyright 2024 ABB

All rights reserved in this document shall be the intellectual property of ABB. No part of this document may be reproduced, stored in a retrieval system, or transmitted in any form or by any means, electronic, mechanical, photocopying, recording, or by any information storage and retrieval system, without express authority in writing from ABB. © Copyright 2004 ABB

Free end wire

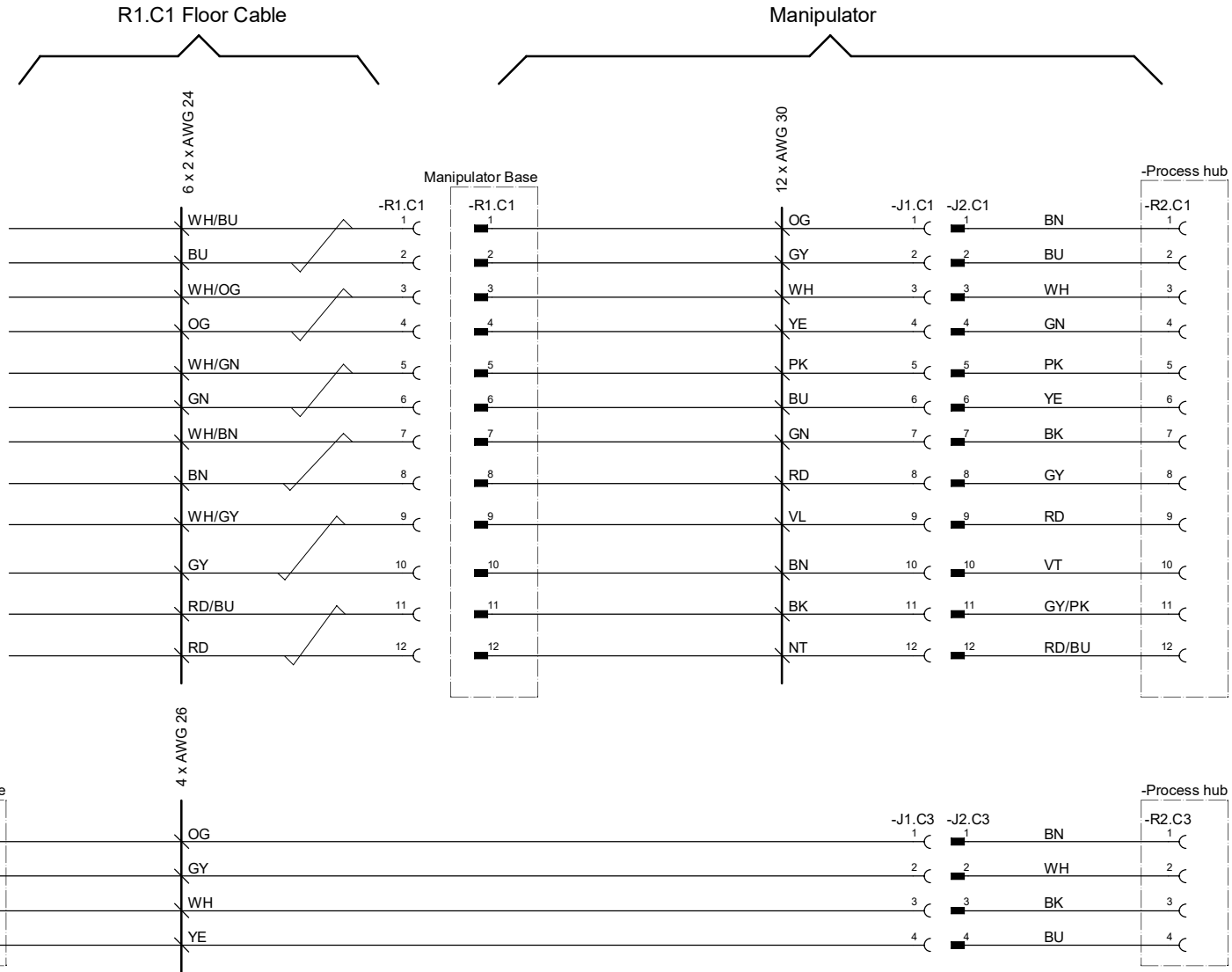

Note : 1) Maximum rating in each C1 wire: 30V, 1.5A. Stresses above the limitation may cause permanent damage to the manipulator.
 Note : 2) Maximum rating in each C3 wire: 42V DC or 25V AC, 4A. Stresses above the limitation may cause permanent damage to the manipulator

Latest revision:
 Add page 17 for valve version
 Adjust C2 harness connection to page 18



Lab/Office:
 RA/RDP

IRB1300
 CUSTOMER CONNECTION - STANDARD

Status:
 Approved

Plant: =
 Location: +
 Sublocation: +

Document no.
 3HAC068887-003

Rev. Ind	Page 16
05	Next 17
	Total 18

Prepared by, date: 10021267

Approved by, date: 10126686

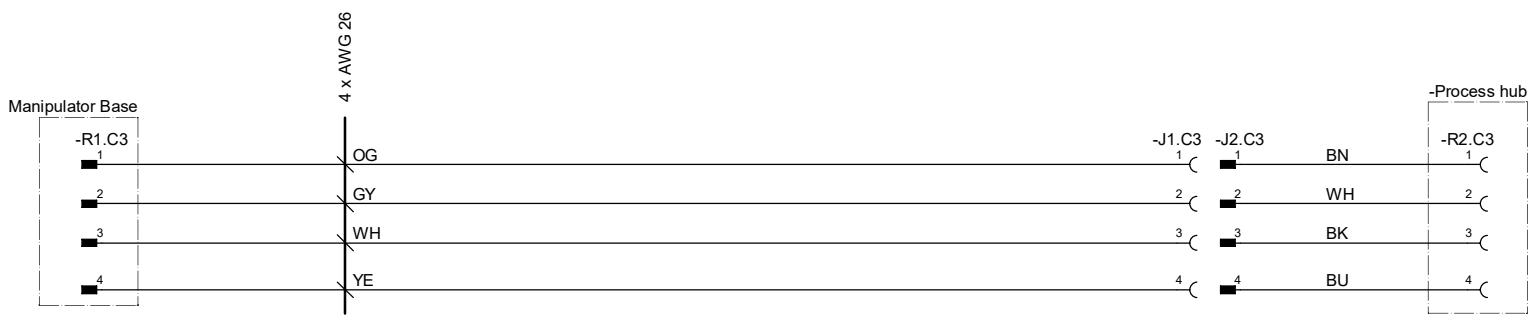
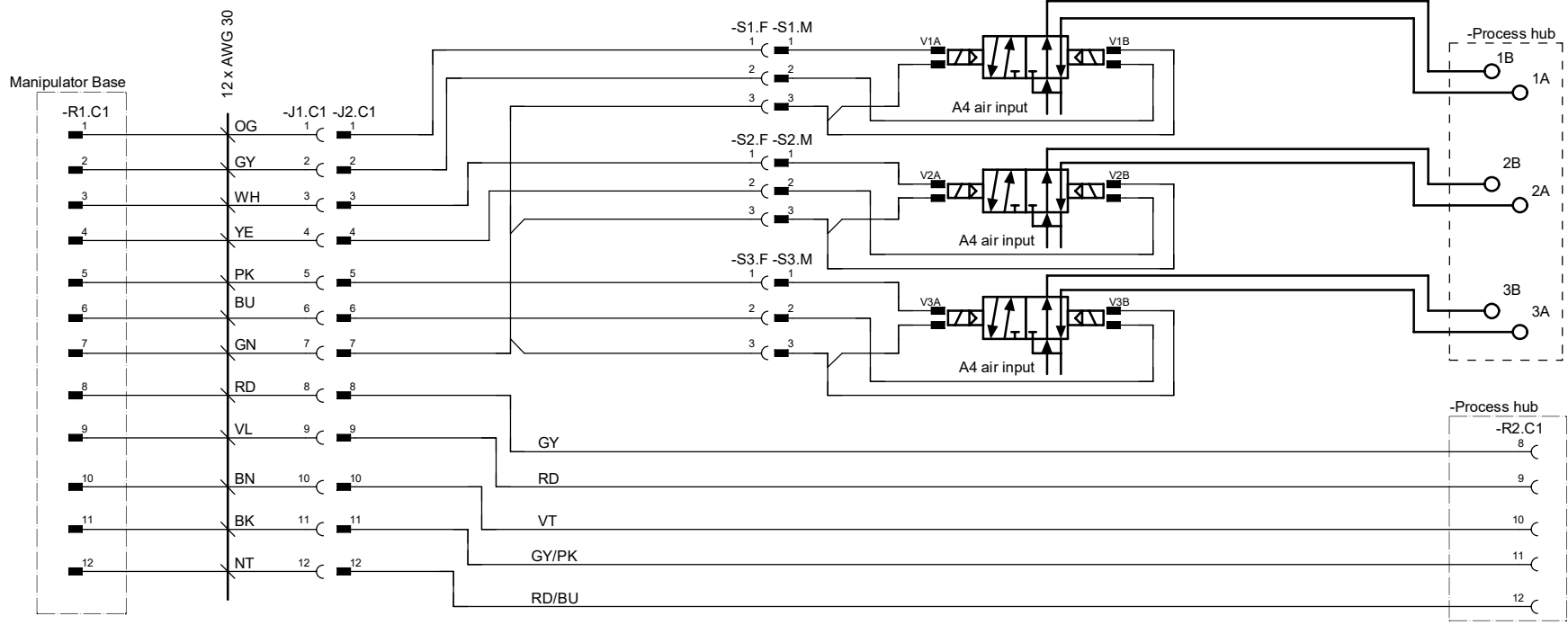

Note : 1) Valve operation voltage (1th ~7th pin): 24V DC ± 10%; Maximum rating in each C1 wire (8th ~12nd pin): 30V, 1.5A.

Stresses above the limitation may cause permanent damage to the manipulator.

Note : 2) Maximum rating in each C3 wire: 42V DC or 25V AC, 4A. Stresses above the limitation may cause permanent damage to the manipulator

Latest revision:
Add page 17 for valve version
Adjust C2 harness connection to page 18



Lab/Office:
RA/RDP

IRB1300
CUSTOMER CONNECTION - VALVE

Status:
Approved

Plant: =
Location: +
Sublocation: +

Document no.
3HAC068887-003

Rev. Ind
05

Page 17
Next 18
Total 18

Prepared by, date: 10021267

Approved by, date: 10126686

All rights reserved in this document shall be the information contained herein, its reproduction, use or disclosure to third parties without express authority is strictly forbidden. © Copyright 2024 ABB

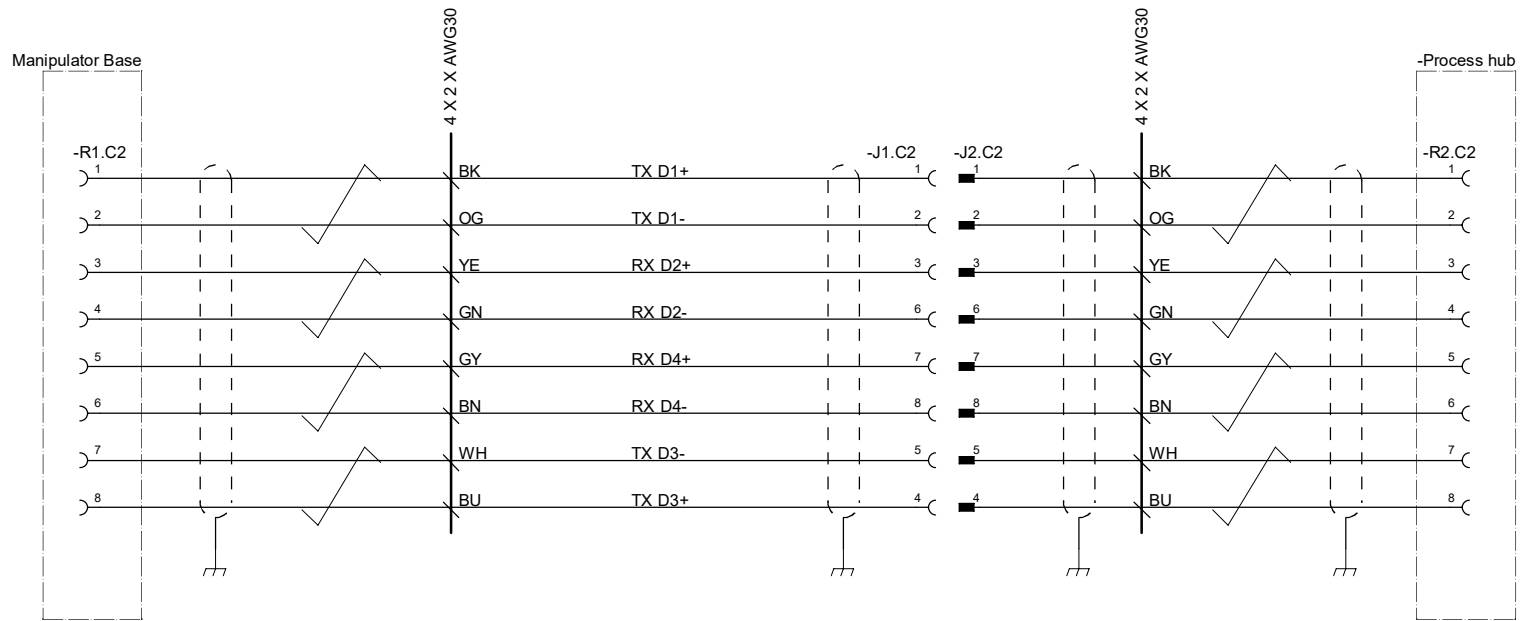

Note : 1): Ethernet cable connecting instruction 3HAC063936-005

Note : 2): Maximum rating in each C2 wire: 30V, 1A (when not using for Ethernet). Stresses above the limitation may cause permanent damage to the manipulator.

Latest revision:
 Add page 17 for valve version
 Adjust C2 harness connection to page 18



Lab/Office:
RA/RDP

IRB1300
 ETHERNET CONNECTION

Status:
 Approved

Plant: =
 Location: +
 Sublocation: +

Document no.
 3HAC068887-003

Rev. Ind	Page 18
05	Next
	Total 18

Prepared by, date: 10021267

Approved by, date: 10126686